

VERSIONS



RIA	RI	AC	HI	HIAC

DIMENSIONS

mm		in		mm		in		mm		in		mm		in			
A	1677	66	D	115	4.5	G	1528	60.2	L	768	30.2	O	1675	65.9	R	695	27.4
B	755	29.7	E	695	27.4	H	1135	44.7	M	722	28.4	P	2010	79.1			
C	1155	45.5	F	2229	87.7	I	740	29.1	N	1677	66	Q	2765	108.9			

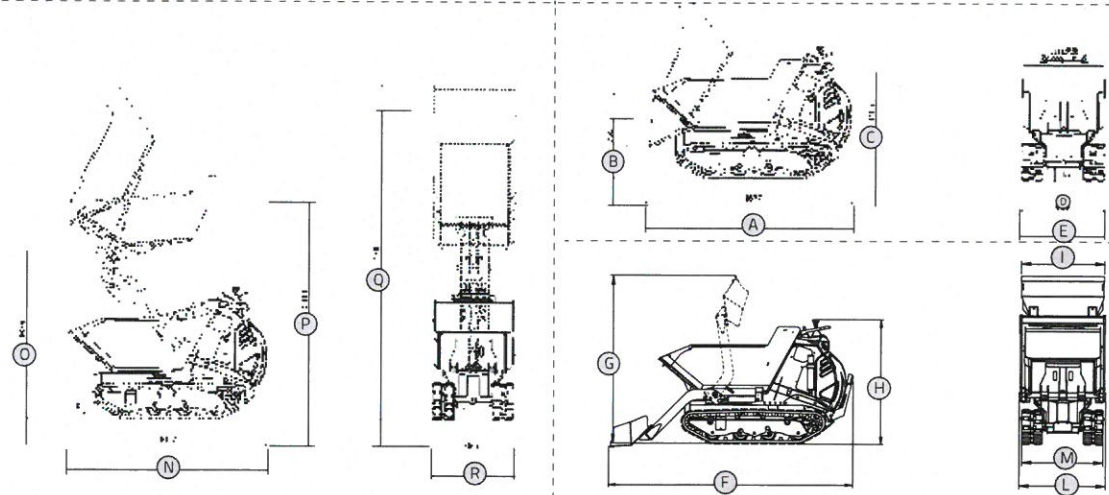

CAPACITY

BE-DE-BHE DHE-ACDHE-DEAC	 WATER 0,15 m ³ 0,2 yd ³	 STRUCK 0,22 m ³ 0,29 yd ³	 HEAPED SAE 0,28 m ³ 0,37 yd ³
RIA		 STRUCK 0,13 m ³ 0,17 yd ³	 HEAPED SAE 0,21 m ³ 0,27 yd ³

TECHNICAL DATA

	METRIC	U.S.	6.60	9.60
ENGINE				
Petrol	Honda GX 270 9 hp			●
Diesel	Yanmar LA 70 7.5 hp		●	
TRANSMISSION				
Type	Hydrostatic		●	●
Hydraulic pump	n°3 Gear pump		●	●
TRACKS				
Crawler width	180 mm	(7.1 in)	●	●
Rocking rollers	Yes		●	●
HYDRAULIC SYSTEM				
Hydraulic pump	Gear pump			
Flow	1x16 l/min	(1x4.2 gpm)	●	●
max pressure	170 bar	(2466 psi)	●	●
PERFORMANCE AND DIMENSIONS				
Max. travel speed	approx 0-3.6 Km/h		(0-2.3 mph)	● ●
Operative weight	600 kg		(1320 LB)	● ●
Weight	BE 463 kg /1021 lb	BHE 552 kg /1217 lb	ACBE 506 kg /1116 lb	ACBHE 628 kg /1385 lb
	DE 476 kg /1049 lb	DHE 567 kg / 1250 Lb	DEAC 520 kg / 1146 Lb	ACDHE 638 kg / 1407 Lb
Vessel contents	0,25 m ³ - 0,33 yd ³		●	●
Parking brake	Yes		●	●

